

LATCH POST WITH FABRICATED PADLOCK HOUSING TO TOP. HEIGHT RESTRICTOR CLOSES INTO LATCH POST FABRICATION AND LOCKING PIN INSERTED. LOCKING PIN IS PADLOCKED IN PLACE. PADLOCK IS PROTECTED FROM VANDALISM BY FABRICATION. (PADLOCK ACCESS FROM UNDERNEATH)

STRENGTHENING FABRICATION MAY VARY ACCORDING TO SPAN

**MAXIMUM HEIGHT
6'11" (2.1m)**

HINGED SECTION MANUFACTURED FROM 100 X 100 X 4mm MILD STEEL SQUARE HOLLOW SECTION.

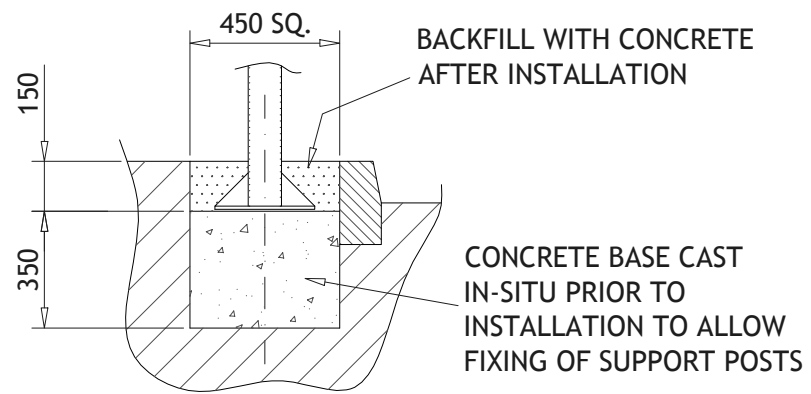

OPTIONAL POST FIXING DETAIL

150 X 150 X 4mm MILD STEEL SQUARE HOLLOW SECTION VERTICAL POSTS

800mm DEEP EXCAVATION TO ALLOW POST INSTALLATION.

SUPPORT POSTS SUNK INTO EXCAVATED HOLES AND BACKFILLED WITH CONCRETE

2100mm CLEAR HEIGHT

2950

700
800

ELEVATION ON HEAVY DUTY PF5600 SINGLE LEAF HEIGHT RESTRICTOR - 1:30

1. HEIGHT RESTRICTOR CAN BE MANUFACTURED TO CUSTOMERS REQUIREMENTS IF NECESSARY.
2. RESTRICTS ACCESS TO VEHICLES UNDER 2.1m HIGH (STANDARD)
3. COMES COMPLETE WITH 'WARNING HEIGHT RESTRICTION' SIGNAGE IN YELLOW/BLACK.
4. GALVANISED OR POWDER COATED FINISHES AVAILABLE.
5. PADLOCK INCLUDED.
6. POSTS MAY BE SURFACE MOUNTED OR SUNKEN (SEE APPLICABLE DETAILS).
7. **PARKING FACILITIES** CAN PROVIDE CIVIL WORKS IF NECESSARY.



Warwick House, Chantry Industrial Estate,
Kingsbury Road, Curdworth, Sutton Coldfield. B76 9EE
Tel: 01675 471122 Fax: 01675 471133
Email: sales@parkingfacilities.co.uk

DRAWN BY :	G. SEAL
DATE :	08/09/03
SCALE :	1:30

TITLE : PARKING FACILITIES - DATASHEET PF5600 HEAVY DUTY SINGLE LEAF HEIGHT RESTRICTION BARRIER	DRAWING NUMBER : PF5600-DS5	REVISION : 'A'
--	-----------------------------	----------------