

HINGED SECTIONS MANUFACTURED FROM 80 X 80 X 3mm MILD STEEL SQUARE HOLLOW SECTIONS WITH 40 X 40 X 3mm CROSS BRACE WELDED DIAGONALLY TO CORNER

HINGED BRACKET SECURED TO ONE LEAF LOCATES ON HASP WELDED TO THE OPPOSITE LEAF. THIS MAY THEN BE PADLOCKED IN PLACE TO PREVENT UNAUTHORISED ACCESS.

**MAXIMUM HEIGHT  
6'11" (2.1m)**

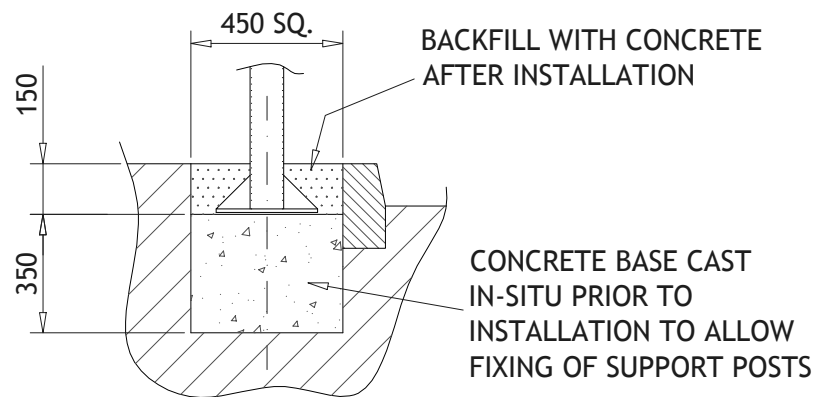

**OPTIONAL POST FIXING DETAIL**

100 X 100 X 4mm MILD STEEL SQUARE HOLLOW SECTION VERTICAL POSTS

SUPPORT POSTS SUNK INTO EXCAVATED HOLES AND BACKFILLED WITH CONCRETE

800mm DEEP EXCAVATION TO ALLOW POST INSTALLATION.

2100mm CLEAR HEIGHT

2055

700  
800

**ELEVATION ON PF5600 DOUBLE LEAF HEIGHT RESTRICTOR - 1:30**

1. HEIGHT RESTRICTOR CAN BE MANUFACTURED TO CUSTOMERS REQUIREMENTS IF NECESSARY.
2. RESTRICTS ACCESS TO VEHICLES UNDER 2.1m HIGH (STANDARD)
3. COMES COMPLETE WITH 'WARNING HEIGHT RESTRICTION' SIGNAGE IN YELLOW/BLACK.
4. GALVANISED OR POWDER COATED FINISHES AVAILABLE.
5. PADLOCK INCLUDED ON DOUBLE AND SINGLE LEAF VERSIONS.
6. POSTS MAY BE SURFACE MOUNTED OR SUNKEN (SEE APPLICABLE DETAILS).
7. **PARKING FACILITIES** CAN PROVIDE CIVIL WORKS IF NECESSARY.



Warwick House, Chantry Industrial Estate,  
Kingsbury Road, Curdworth, Sutton Coldfield. B76 9EE  
Tel: 01675 471122 Fax: 01675 471133  
Email: sales@parkingfacilities.co.uk

DRAWN BY :	G. SEAL
DATE :	24/08/02
SCALE :	1:30

TITLE : PARKING FACILITIES - DATASHEET PF5600 DOUBLE LEAF HEIGHT RESTRICTION BARRIER	DRAWING NUMBER : PF5600-DS1	REVISION : B
---	-----------------------------	--------------